

Market Lamb

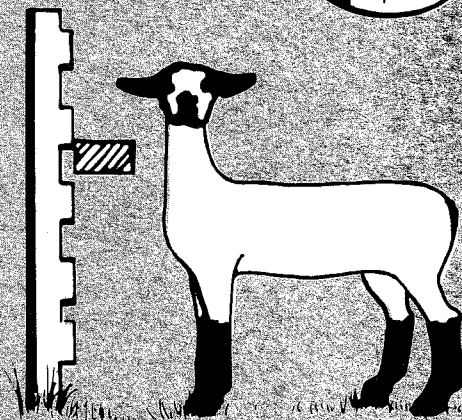
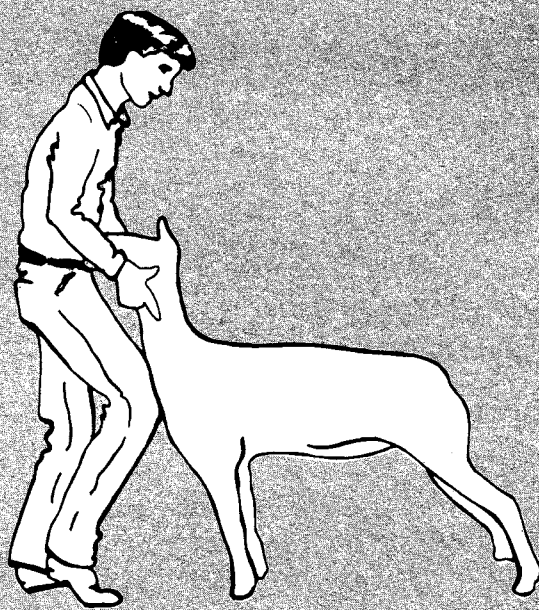

4-H Member's Manual

Market Lamb 4-H Member's Manual

Table of Contents

Introduction	1
Plan Your Project	1
Project Considerations	1
Facilities	1
Selecting a Market Lamb	4
Feeding and Management Tips	6
Animal Health	8
Exercise Areas	9
Catching and Training Your Lamb	11
Fitting for the Show	12
Showmanship	14
After the Show	16
Show Checklist	17
Glossary	20

Market Lamb

4-H Member's Manual

Introduction

Welcome to the 4-H Market Lamb Project. Raising lambs requires a small investment, a small area, and some equipment. Producing market lambs is an interesting and rewarding experience for the entire family.

You will learn some basic sheep husbandry and develop your own character and personality. The project gives you a chance to learn how to accept responsibility and assume leadership. As you raise your lambs, you will deal with people and experience the rewards and disappointments of competition.

Plan Your Project

When beginning your project you must first plan what goals you want to work toward and achieve. To help you plan your project, you may want to follow these steps:

1. Meet with your parents and 4-H leader to list objectives. Decide what shows you plan to exhibit your lamb, and what you will need to reach the goals you set.
2. Read and *study* the material provided in this manual. If you do not understand something, seek help from your parents, leaders, county extension agent, or extension specialist.
3. Start and follow through with the plan you have set up.
4. Share your experience with your 4-H club by giving presentations or recruiting fellow 4-H'ers to have 4-H market lambs next year.

Project Considerations

You may not make money when you feed lambs for show. It costs more to feed show lambs than it does to feed lambs in commercial feedlots. You will probably find that feed costs, the price of the lambs, and equipment costs are higher than they would be for commercial production.

If you enroll in the 4-H market lamb project just to make money and do not consider the value of what you can learn from the project, you may be disappointed. Be ambitious and enthusiastic about your project and immediately attend to all of the details involved with the selection, feeding, health, fitting, showing, and marketing of your lambs. You will be pleased with your accomplishments when the project is completed.

Facilities

You do not need a fancy showbarn or expensive facilities when feeding lambs. You need only a few things for a market lamb project. Perhaps you already have shelter, water, and shade that you can use. These should be on a well-drained area with access to an exercise area or pasture.

All facilities must be predator proof. The feeding area must be rodent and animal proof. Keep chickens, cats, dogs, and mice out of the feed, and maintain a clean, healthy feeding environment.

A combination facility will give the lambs access to shelter and an exercise area. A simple well-constructed shed with the open side facing south works well. The shed should provide 10 to 12 square feet of space for each lamb. It should also have room for hay and grain feeders. The shed should be open, so the lambs get plenty of ventilation during warm weather. You can usually modify existing barns or sheds to house your show lambs. Dirt floors (well bedded with shavings, sawdust, or straw) keep the lambs comfortable.

Movable Shelter

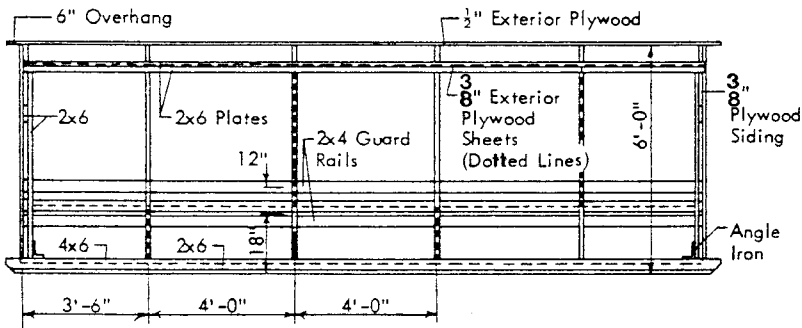
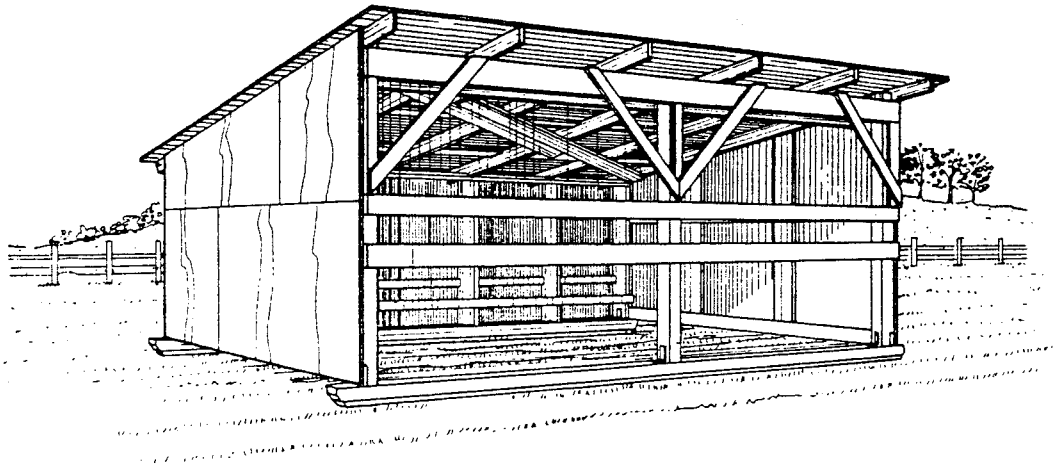

Back Side Framing

Note:
Plywood sheets indicated by dotted lines. Cover roof with roll roofing.

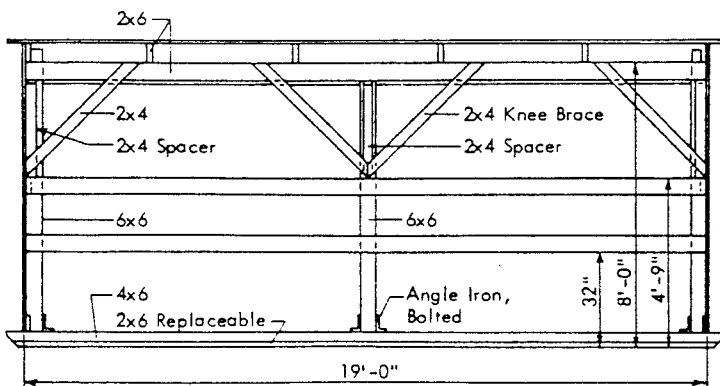

Front Side Framing

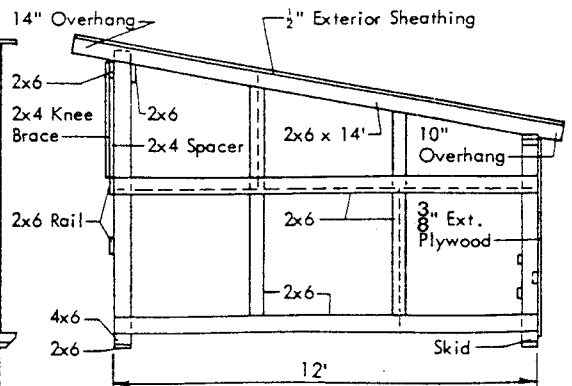

End Framing

The outside area will vary in size due to convenience. However, give the lambs ample room to run. About 100 to 200 square feet per lamb should be sufficient. The outside area needs to be enclosed with a dog proof fence, 42 to 60 inches high.

A lamb shed (Diagrams 1 and 2) may be constructed from two sheets of 4' x 8' plywood (exterior grade) and 2" x 4" framing. It is enclosed on three sides, covered, and has a vent window in back. You might also construct an outside pen by using 2-inch top diameter posts with the posts on 6-foot centers, leaving the posts 5 feet above ground level. The gate should be 2' x 5' and constructed of 2" x 4" lumber covered with wire (Diagram 3).

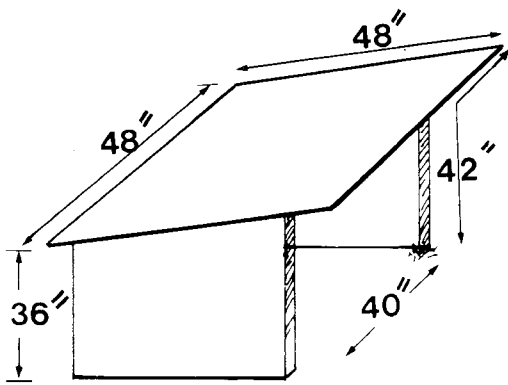

Diagram 1

You can make this shed with two sheets of plywood.

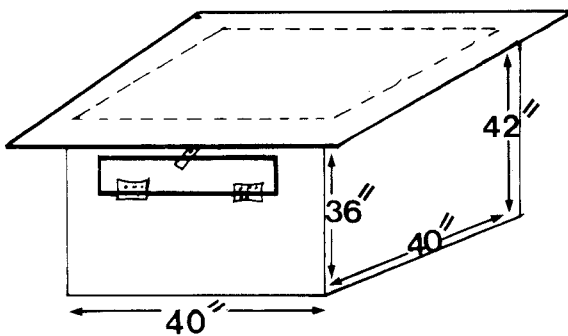

Diagram 2

The vent window in the back allows air to flow through the shed.

Shade

Shade is extremely important in hot summer months. Lambs will not eat properly or gain satisfactorily without some protection from heat.

The best shade is open on all four sides, allowing for maximum ventilation. The shade should be at least 20 feet by 30 feet and 6 or 7 feet high. This much area is needed to get a proper cooling effect. A shaded area this size would be large enough for 10 to 15 lambs. If you can make a larger shaded area, it will be more effective.



Large trees are an ideal source of shade.

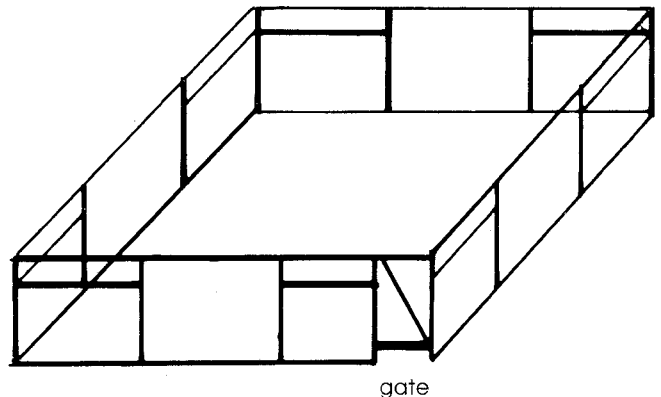

Diagram 3

An outside area allows lambs room to run.

A constructed shade (Diagram 4) can serve a dual purpose by also providing shelter. When constructed so that two or preferably three sides can be closed, it

will provide adequate protection from sudden rain or windstorms. Shelter is particularly important when you have to keep the lambs clean.

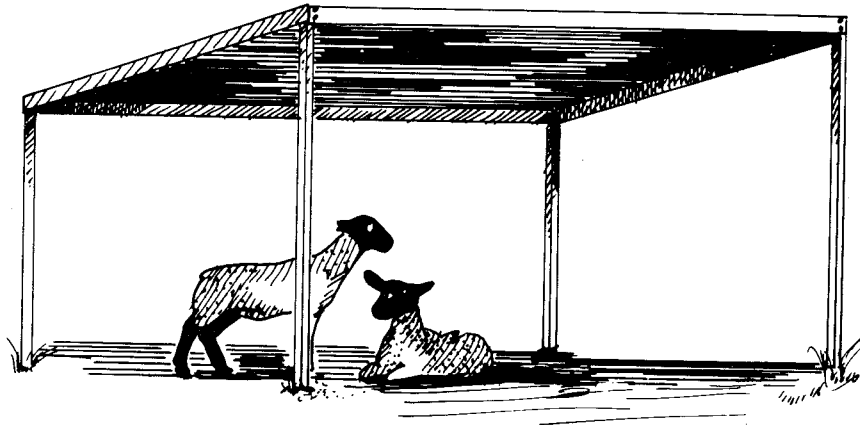

Diagram 4 You can build a shelter or shed to provide shade and help keep lambs cool.

Selecting a Market Lamb

Selection of your lamb will be the most important part of your project. You can feed the best rations and feeds and do an excellent job fitting and showing, but your lamb's genetics and type are something you cannot overcome. It is important for you to select a good lamb from the start. For best results, select quality, healthy lambs from reputable people. If possible, look at the lamb's sire and dam before making a final decision. If you are not sure about picking your lamb, ask for help. Pick someone who knows how to select lambs. This might include your county extension agent, parents, area extension specialist, or a neighbor. These people are interested in your success with your sheep.

Consider four basic areas when selecting your market lamb project: (1) weight; (2) frame and growthiness; (3) muscle; and (4) structure, balance, and eye appeal. Champions are heavy muscled, structurally correct, nicely balanced lambs that are correctly finished.

Select your lamb on the basis of the show date you have targeted. Consider the weight of the lamb that you are buying. The lamb should gain 0.4 to 0.6 pound per day when properly fed. If you know the number of days before the show and you want your lamb to weigh 90 to 125 pounds at the show, you can calculate how heavy your lamb should be at the start of your project.

Frame size is related to market weight. Small-framed lambs mature and fatten earlier, thus they are shown or marketed at lighter weights. Large-framed lambs can be marketed at heavier weights. Try to select lambs that are upper-medium to large-framed. However, do not select extremes as you want the lambs to be in your show's weight range. Excessively large-framed lambs may exceed the weight limit. If they do not exceed the upper weight limit, they usually do not have enough muscle for their frame.

Your lamb should be heavy muscled, with a wide, long loin and a thick, heavily muscled leg and stifle. However, use caution when selecting young lambs. Excessively thick, bunchy muscled lambs may mature early and will become coarse and off-balanced.

Your lamb should also be structurally correct and nicely balanced. Select lambs that set their feet squarely at all four corners. Structure problems tend to be more noticeable as lambs get heavier. Also, select lambs that are nicely balanced, trim fronted, long hipped, and free of wrinkles. A good eye appealing lamb that is free of wrinkles will handle firm when finished. If a lamb has eye appeal when it is young, it should maintain this eye appeal. This will result in the lamb catching the judge's eye. Lambs that hold up their heads are usually easier to show and the first ones to be noticed.

One last thing to remember when selecting your market lamb is age. As a feeder and exhibitor, your responsibility is to have lambs less than one year of age at showtime. However, going to a reputable

breeder should remedy this factor. Be sure to explain to the breeder your goals and show schedule. Most breeders will help guide you in the right direction.

Rear view measurements

- a. Length of neck
- b. Overall length
- c. Foresaddle or rack length
- d. Loin length
- e. Rump or hip length
- f. Depth of twist
- g. Length of leg
- h. Width of stance
- i. Width of stifle
- j. Width of rump
- k. Stifle area
- l. Crotch or twist
- m. Inside leg muscle
- n. Width of pin bones
- o. Outside leg muscle
- p. Hock

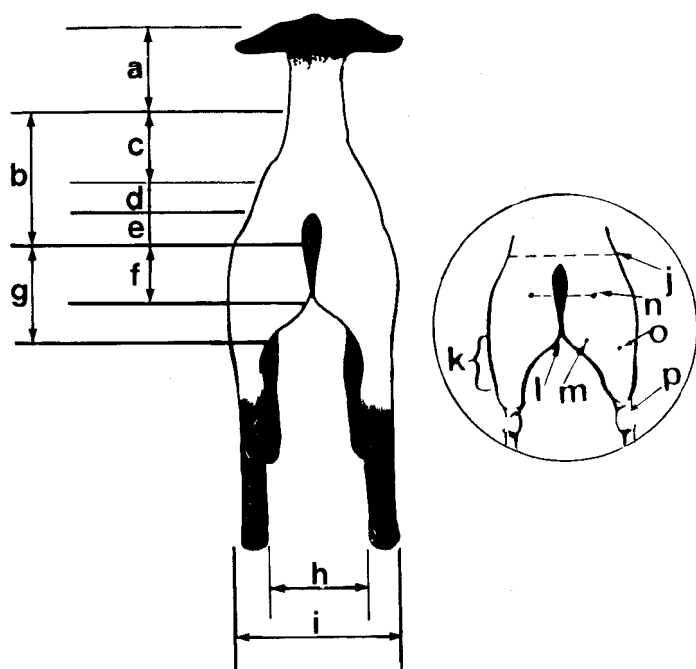

Side view measurements

- a. Overall length of top
- b. Foresaddle or rack length
- c. Hindsaddle length
- d. Loin length
- e. Rump or hip length
- f. Length of leg
- g. Depth of chest
- h. Height from ground
- i. Overall or shoulder height
- j. Diameter of leg or length of stifle
- k. Pastern
- l. Diameter of forearm
- m. Diameter of cannon bone
- n. Point of shoulder
- o. Length of neck
- p. Dock

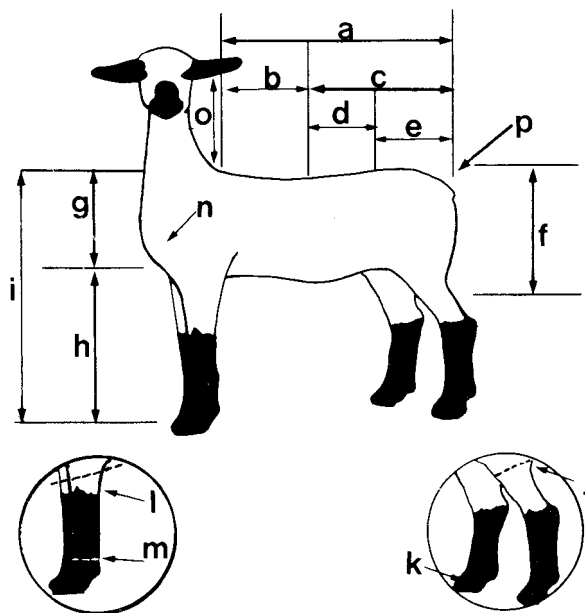

Feeding and Management Tips

When taking on a market lamb project, one goal should be to provide a balanced diet that will allow your lamb to grow at the designated rate. When purchasing market lambs, you should consider feeding your lambs in three phases: starting, growing, and finishing.

The **starting** phase is a ration in which the lambs get used to eating out of a bunk or trough. This phase allows for proper rumen development and may require extra health care. The ration should set the stage for the growing phase. It should allow the lamb to move into the growing phase with few setbacks.

The **growing** phase is a time of gradual increases in feed and energy. As your lamb grows, the amount and kind of feed need to be changed. Be sure to make changes in the ration slowly to prevent your lamb from going off feed. During this stage of feeding, your lamb should be **increasing** in both skeletal and muscle size. However, little fat growth is evident.

The length of time that a lamb is in the growing phase depends on the lamb's genetics, environment, and the amount of time before the show.

The **finishing** phase is one that also varies with each animal. The length of time in this phase depends on the lamb's condition when leaving the growing phase. Lambs that are almost ready to be marketed need less time than thin, underconditioned lambs.

Several commercial lamb feeds are available in ground or pellet form. However, these feeds may be more expensive than mixing your own rations.

The first step in balancing a ration is to look at the daily requirements of the animal. The current requirements of a market lamb are given below.

If you wish to mix your own, some suggested rations are given. Remember that trace mineral salt should always be available in a dry, weather-proof area.

Lamb Weight (lb.)	Expected Daily Gain (lb.)	Protein(%)	TDN(%)	Calcium(%)	Phosphorus (%)
45 -110	.4 - .5	12 - 16	65 - 75	.28 - .35 (up to 1.0)	.18 - .25 (up to .50)

Concentrate Mixes for Developing Show Lambs

	Ingredients	Starting (%)	Growing (%)	Finishing (%)
Ration 1	Oats	65	40	20
	Corn	20	40	65
	Soybean Meal	15	20	15
Ration 2	Corn		65	70
	Soybean Meal		20	15
	Wheat Bran		15	15
Ration 3	Ground Ear Corn		70	75
	Soybean Meal		25	20
	Dry Molasses		5	5
Ration 4	Corn		15	25
	Wheat		30	30
	Barley		35	35
	Soybean Meal		20	10

Growing and Finishing Rations

Pounds of Feed Per Head Per Day

Body Weight	Growing (72% TDN)		Finishing (75% TDN)	
	50 lb.	75 lb.	100 lb.	125 lb.
Ration 1	2.00	3.00	3.25	3.75
Hay *	.50	.75	1.25	1.50
Ration 2	1.75	2.75	3.25	3.75
Hay *	.75	1.00	1.25	1.50
Ration 3	2.00	3.00	3.50	4.00
Hay *	.50	.75	1.00	1.25
Ration 4	1.75	2.75	3.25	3.75
Hay *	.75	1.00	1.25	1.50

* Average quality grass/legume hay, TDN = 55%; crude protein = 10%

Note: A good rule of thumb is to feed the lambs what they will consistently clean up in 30 minutes when fed twice a day.

Feeders

Hand feeding your lamb is highly recommended. This encourages you to observe your project each day. You can hand feed by using portable troughs hung on a gate or fence. Troughs should be hung so the bottom of the trough is parallel with the top of the lamb's shoulder. After feeding, the trough needs to be removed and cleaned. Do not put minerals and hay on the ground.

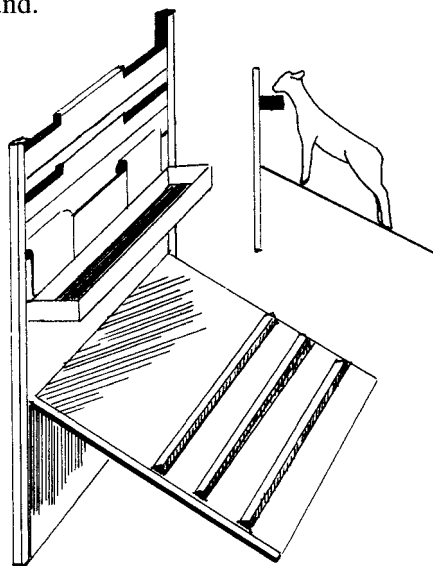

Diagram 5 Ramp feeders can be used to help build leg muscles.

Other methods of feeding are also used. The idea behind the “ramp” feeder (Diagram 5) is to keep the head high and help build the leg muscles. Cleats should be for hind feet only and not placed too far back. Gradually raise the feeder as the feeding period progresses. Feeding lambs in a chin-high feeder (Diagram 6) helps to keep their heads high, alert, and tighter-shouldered. You might also use an

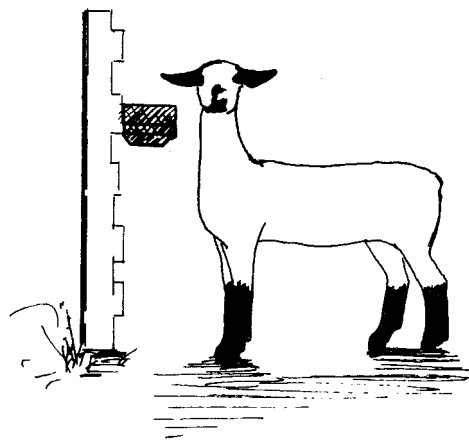

Diagram 6 Place the feeder chin high to the lamb.

elevated feeder (Diagram 7). This type feeder transfers weight to the rear legs, aiding in muscle development. Make sure to allow 16 inches of bunk space per lamb that you are feeding.

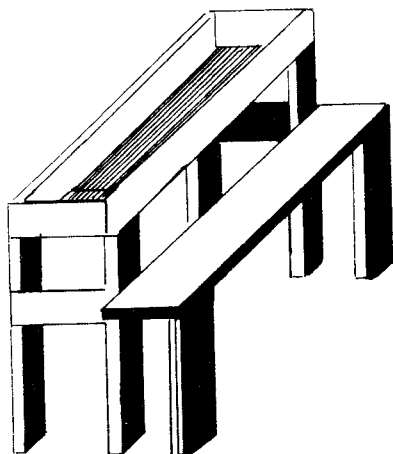

Diagram 7 Elevated feeders cause weight to be shifted to the rear legs to help build leg muscles.

Water Containers

Clean water is essential when raising lambs. The water trough needs to be cleaned and placed in the shade. Usually, while the lambs are eating, the water buckets or trough can be cleaned. Sheep will not drink dirty water. If the lambs do not drink water, their daily weight gains will decrease. Fresh, clean water is essential for lamb performance and health. Plastic tubs and water-heater tanks cut in half work well (Diagram 8). Buckets also work well as waterers, as long as they are kept full.

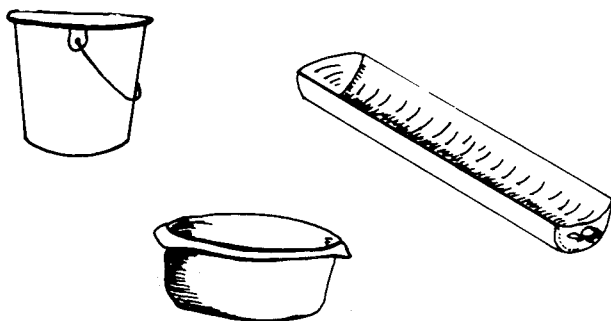
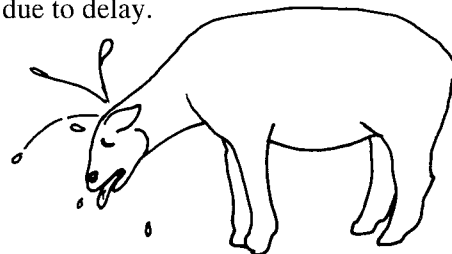

Diagram 8 Many types of containers can be used to provide water for lambs.

Animal Health

Like people and other animals, sheep can get sick. They require vaccinations to protect them from diseases. Your sheep may also become injured. You and your parents may be able to treat and care for them in some cases. If the situation is serious, a veterinarian may be needed. Whatever the case, be prompt in your care to avoid complications that may arise due to delay.



A sick lamb will first show signs of illness by loss of appetite, head down, droopy ears, and a general lack of energy.

Prevention is the easiest and most profitable method for disease and parasite control. When your lambs are purchased, they should have their feet trimmed and be dewormed. They should also be vaccinated for enterotoxemia and tetanus. You may also want to vaccinate for soremouth to prevent it from occurring.

By giving lambs plenty of exercise and watching them at each feeding, you should be able to spot sick lambs quickly. The first signs of a sick lamb are loss of appetite, head down or carried low, droopy ears, and a general lack of energy. If you notice these signs, find the problem and use the proper treatment. Consult your veterinarian or county agent on appropriate vaccines and antibiotics.

Internal parasites tend to be the most often encountered health problem in sheep. Deworm your lambs at the start of your project and every 30 days following the first deworming. Many dewormers are available with different ways of administering them to the sheep. Drenches, boluses, injections, and paste dewormers are all acceptable. Whether you use a drench, bolus, or paste dewormer, be sure that the lamb does not spit it out. Under-dosing or not giving enough of the dewormer does not help in controlling internal parasites. Note the withdrawal times of the products before administering. If you are not sure of what product to use, contact your agent or veterinarian for advice.

Footrot is a highly infectious disease caused by bacteria that live in the soil. The bacteria can get in the foot or hoof. The first symptom is lameness or soreness in one or more of the feet. Infected feet will have a foul smell when trimmed. Routine trimming of the feet will help to prevent and control this disease. When the bacteria are exposed to the air, they die.

Instruments you can use to trim the feet include a sharp pocketknife, side cutters, or hoof trimmers. When trimming the feet, trim the outside even with the pad of the foot. This will help prevent the packing of mud and other material into and around the hoof and will keep bacteria from entering the foot.

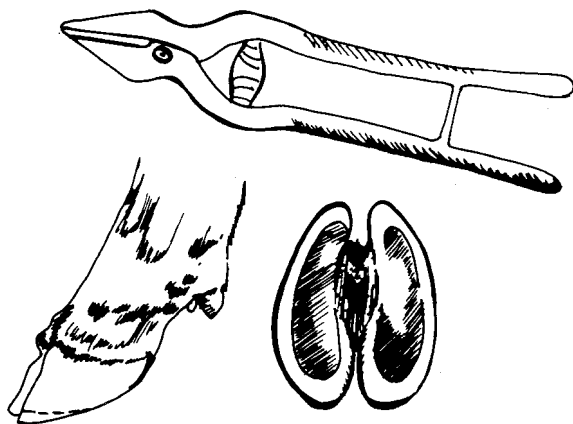

Trim only the outer wall of the hoof, indicated by dotted line.

Enterotoxemia, known as overeating disease or pulpy kidney, is common in fast-growing young lambs on high concentrate diets. The disease is caused by a toxin from the bacteria *Clostridium perfringens*. The best prevention is vaccination for bacteria types C and D. A booster shot should also be given to the lamb about four weeks after the first injection or according to label directions. The injections should be given on the lamb's left side under the skin or in the flank. The lamb's left side and the flank are not the "show side" and are not seen as often. The injection may leave a small lump.

Tetanus is a disease caused by the bacteria *Clostridium tetani* and is sometimes called lockjaw. This organism also lives in the soil, especially where horse manure is present. Vaccination is the best prevention to avoid the disease.

Exercise Areas

Top lamb feeders and competitors recommend exercise regimes that build muscles and firm up your lambs. Although exercising lambs is not practical in the commercial industry, it is the popular thing when preparing for a show. Each lamb should be exercised as needed. This depends on the lamb's condition and weight. A properly conditioned lamb should have 0.15 to 0.25 inch of fat over the rib and down the top. To get a good handle on what this feels like, make a fist. Press on the back of your hand. This would be close to the pressure needed to feel the bone of a lamb with 0.15 inch of backfat. Lambs that are finished correctly need to be walked or exercised only a quarter to half of a mile a day. Lambs that are overfinished will need more exercise.

When starting an exercise program, begin slowly and increase to longer workouts. Always exercise your lamb in the coolest part of the day. Do not let your lamb get overheated. If lambs get overworked, weight gain will decrease along with the amount of finish.

Many exhibitors use jumps and exercise alleys for their lamb projects. However, this practice could cause injury to the lambs. The best exercise is to walk your lamb away from the barn a quarter of a mile. Then, if it is possible and safe to do, turn the lamb around and let it run back to the barn. Only do this after you have led it back to the barn a few times. The lamb will beat you back to its home.

If you decide to use jumps, a few tips may help prevent a mishap. Railroad ties, small barrels, boards, and fence posts may be used as jumps or hurdles. The exercise area can be a long fenced-in alley, a circle alley 5 to 10 feet wide, or an alley either surrounding or on the way to the feeding area. When constructing your exercise facilities be sure not to have abrupt, sharp turns or corners in the alley way. These will allow lambs to pile up and possibly get injured.

Making A Rope Halter

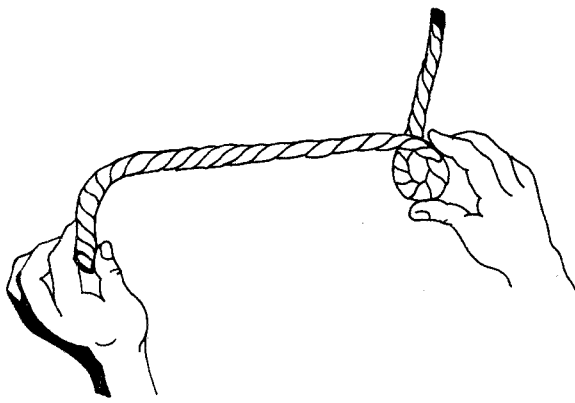

Figure 1

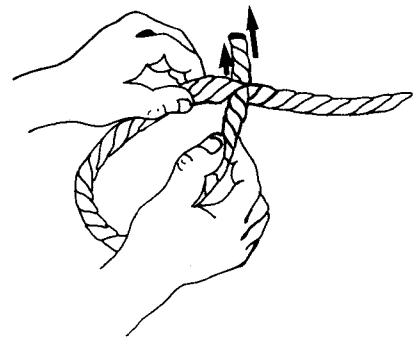

Figure 2

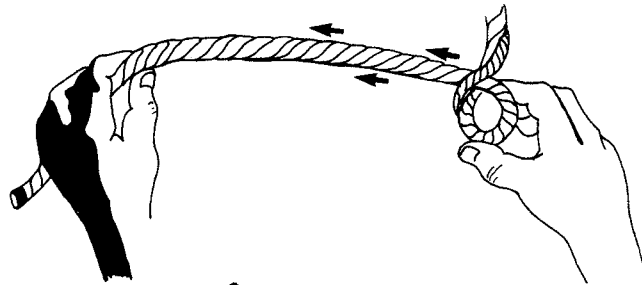

Figure 3

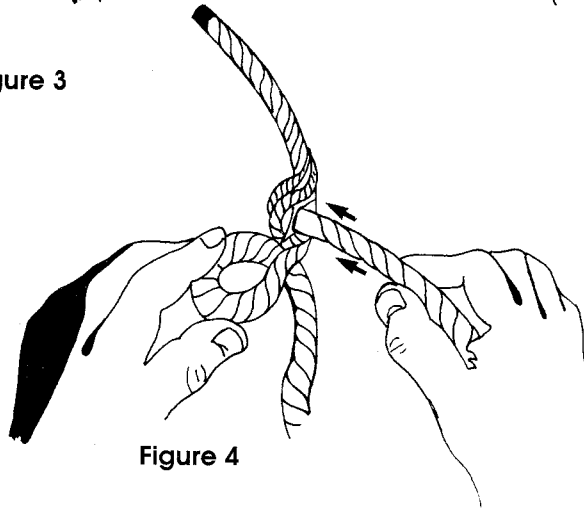

Figure 4

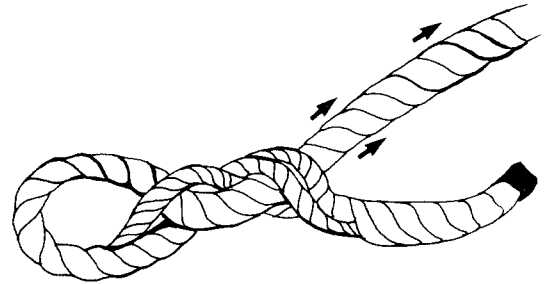

Figure 5

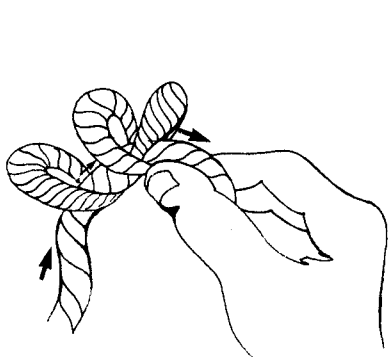

Figure 6

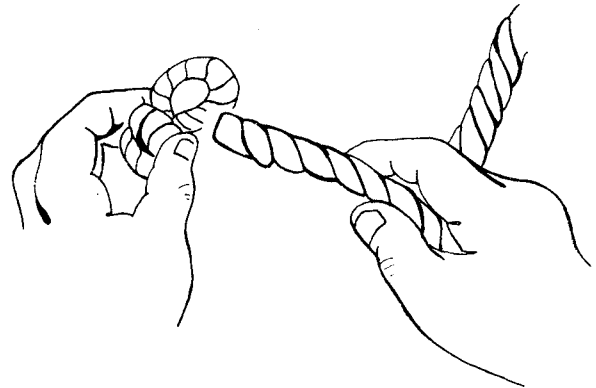

Figure 7

Catching and Training Your Lamb

Do not tackle or grab your lamb by its wool or skin. This may cause bruising and the lamb to handle soft, which may cause the judge to think you have a fat lamb.

The best way to catch your lamb is by or around the neck or the rear flank. When the lamb is caught by the rear flank, grab the flank with a full hand. Then pick up as if you were lifting the lamb off its feet. Avoid pinching the flank or grabbing the lamb by the rear leg, as an injury may occur. Once you stop your lamb by either catching it by the neck or the flank, grasp under the jaw lightly with your left hand. Do not pinch your lamb. Then put your right hand on the back of the head to have more control of the lamb. Use your left hand as a guide when moving the lamb. If the lamb starts to move too fast or you want to stop, tilt the lamb's nose up and pull back. This motion should cause the lamb to stop. Sometimes it is hard to get a lamb to start walking. When this happens, use your right hand to pull up the dock which urges it to move.

For ease of handling and walking your lamb, halterbreak it. The key to halterbreaking your lamb is to start early. Make your movements slow and easy. Be patient because the lamb will be jumpy and nervous at first.

You may purchase a halter, but making one may be more convenient and much less expensive. An easy-to-make adjustable rope halter is called the "1-2-3"

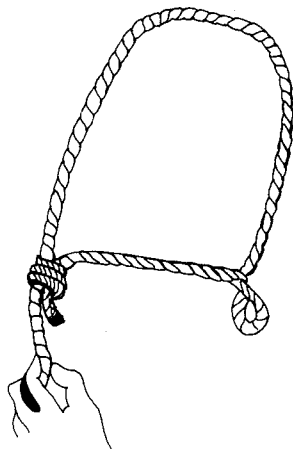

Figure 8

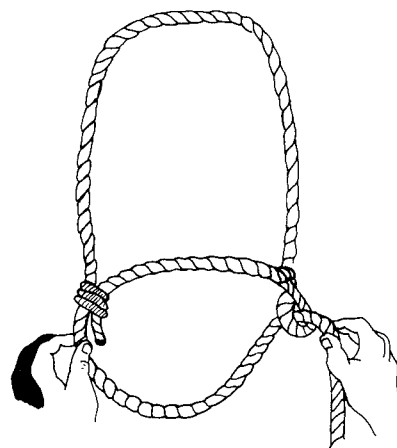

Figure 9

halter. You begin with a 6- to 7-foot length of nylon three-strand rope. Though nylon rope is more expensive, it does not shrink when it gets wet. Nylon rope is recommended and easier to work. The ends of 3/8-inch diameter nylon rope should be heat fused to prevent fraying.

To make a rope halter, make an eye (Figure 1) by looping the short end of the rope over the long end (about 6 1/2 to 8 inches from the end of the short end). This length will depend on the size of lamb for which the halter will be used. Pull the short end of the rope under one strand of the long section of the rope (Figure 2). Adjust the eye opening to about twice the size of the rope (Figure 3).

For step two, pull the long end of the rope under two strands of the short end (Figure 4). When you pull the long end tight, you will have a smooth surface of three strands together which will go toward the lamb's head (Figure 5). About 1/2 to 1 1/2 inches from the short end of the rope, pull and twist one strand at a time in a counter-clockwise direction. Do this for the other two strands to complete step two (Figure 6).

Pull the long end of the rope through the loop farthest from the end of the rope (Figure 7). Pull the long end through the other two loops (Figure 8). If using a manila rope, leave an inch or two at the end of the rope beyond the three loops. If manila rope gets wet, it will shrink. Make sure the end beyond these loops points away from the lamb's eye when the halter is on the lamb. Pull the long end of the rope through the eye made in steps one and two (Figure 9).

The finished halter should have the lead rope on the lamb's left side. Place the halter on your lamb so the lamb can be led from its left side. Let the lamb drag the halter for a couple of days to make it aware of the halter. After the lamb drags the halter, you should try to lead your lamb. This is the hardest task of all, but it is very important.

Be sure to place the halter on the lamb's head properly. The section of rope that goes over the nose should be only an inch or two from the eyes. Do not put the rope on so that it is near the mouth. This halter can be adjusted up or down by moving the twisted section (Diagram 9, p. 12) along the rope.

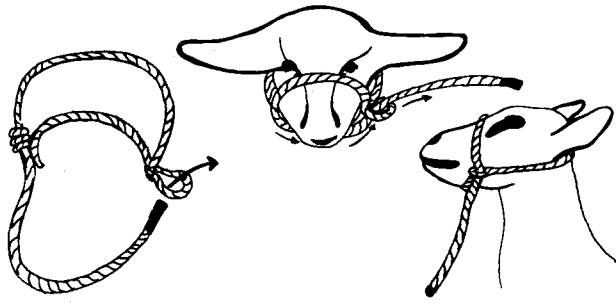

Diagram 9 Correct halter placement shown.

To begin halterbreaking your lamb, tie it, using a slip knot, to a post or fence. Be slow in your motions and talk to your lamb, so the lamb knows that you are not going to hurt it. Practice setting the feet up while the lamb is tied and cannot get away. This will also help make the lamb gentle. Then lead your lamb to the feed bunk or water. This will allow it to associate leading with a reward of feed or water. Then start leading it around the barnyard. Keep a firm grip on the halter, close to the lamb's head. Grab over the rope so your thumb is closest to you. Do not grab the halter under the rope, so that your thumb is closest to the lamb. You have better control by grabbing over the rope and are less likely to be hurt.

Teach your lamb to stand properly for long periods of time. This requires much time and patience. The legs should be set at all four corners, and the lamb's weight should be distributed evenly on these legs. Repeat this lesson several times each night until the lamb stands still for several minutes at a time. When you are finished working your lamb, feed it and let it loose to exercise. The best way to get your lamb trained is to spend time with it. The more time spent at home with your lamb, the easier the lamb will be to handle at the show.

Fitting for the Show

Washing the Lamb

Lambs can be washed with a hose; however, the lamb should be tied to a gate or placed on a fitting stand. You can use a large container and give the lamb a bath, except for fine wool sheep. Most exhibitors use the first method and haul less equipment to a show.

Start by rinsing off the lamb. Start at the legs to let the lamb get used to the water, and work your way up

the lamb's body. Do not start by spraying cold water on the lamb's back; this will scare it. Also, try to avoid getting water in the lamb's ears by covering them with your hand. Once the lamb is wet, apply a mild liquid soap by rubbing it on your hands and then onto the lamb. Do not apply or squirt the soap directly on the lamb. These concentrated areas of soap are hard to rinse out and could cause severe dandruff. While washing, remove all dirt and manure. A currycomb or stiff brush may be helpful in loosening those extra dirty spots. Be sure to rinse the lamb thoroughly to remove all of the soap.

Dry your lamb with an animal blower or towels. If you are going to shear the lamb after washing it, merely remove the excess moisture. The lamb does not need to be completely dry.

Shearing Equipment

Many types of electrical large animal clippers are available. The motors are very similar in the speed that they move the cutter blade over the comb blade. The heads of these machines come in different sizes. One size is 2.5 inches wide, while the other available clipper heads are 3 inches wide.

The 2.5-inch head has only one sheep comb that fits. This comb has only 10 teeth and leaves ridges of wool during the shearing process. This machine is excellent for regular flock shearing but is limited in its effects on show sheep. However, if flat head clippers are available, the two machines together will result in a smooth clip on your lamb. Simply shear the lamb with the 2.5-inch sheep shearing machine; then dampen the wool and use the flat head clippers to shear the entire lamb. These flat head clippers are very good for the small exhibitor; it is extremely difficult to cut the lamb or yourself.

The 3-inch machines are more versatile, and a wider variety of combs is available. The combs available allow the fitter to make some decisions on what to use based on shearing experience. The best blade for a close cut and greater safety from cutting or nicking the lamb is a 20-tooth goat comb.

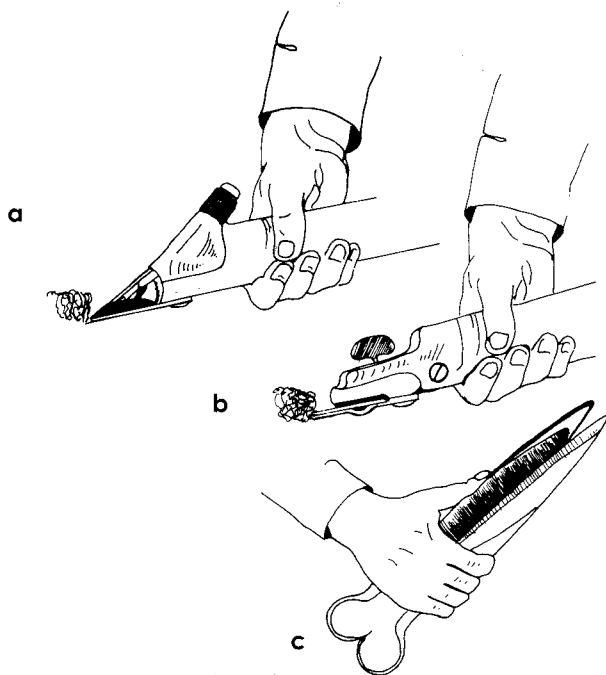

The shearing head (a) with a 20-tooth goat comb is used to shear. The flat head (b) is safe for beginners and is used to smooth out cuts. A hand shear (c) is used to trim long wool when it is damp.

Shearing

North Carolina does not have any specifics on shearing styles. This allows you freedom to fit your lamb the way your lamb looks the best. However, two basic methods are used most frequently in fitting or shearing lambs—slick shear and fitted. You may choose either method. For both methods, it is highly recommended that you wash your lamb before shearing and shear the lamb no earlier than seven days before the show.

Slick shear results in the least amount of work when preparing for a show. You will shear the lamb as described below to allow the vertical and horizontal lines to help its appearance. Start by opening the fleece at the forearm/shoulder area with strokes that are vertical from the knee to the top of the shoulder. After the fleece is opened in the shoulder area, use horizontal strokes to shear the sides, belly, and top of the body. Clip the rear legs from the hock to the hooks in an angled vertical motion removing all of the wool. Leave the wool on the legs below the knees and hocks to give the appearance of a heavy bone structure. The wool on the inside of the legs should be clipped shorter, using hand shears to make the lamb appear wider standing and thicker.

Shear the neck using lengthwise strokes to emphasize length. To do this, remove the lamb from the fitting

stand or table's head yoke. With the lamb on the stand, straddle the lamb and bend the head to one side. This will stretch the lamb's skin for a smoother cut from the brisket or breast area to the chin. You may need someone to stand behind the lamb to assure yourself that the lamb will not fall off the fitting table. (See Diagrams 15 and 16, pages 18 and 19.)

Use the small animal clippers to clip the head and ears. Be sure not to clip the eyelashes or the long whiskers by the mouth. If these whiskers are sheared off, the lamb may go off feed or quit eating. You may want to leave the wool from the ears forward. This area can be carded and trimmed with your hand shears.

The **fitted** method combines slick shearing and wool fitting. The lamb is slick sheared from the hooks forward, leaving wool on the rump and leg area. The rump and leg wool is carded and hand trimmed to look meatier. This extra wool should blend in smoothly with the rest of the sheared body. Do not leave the wool too long (3/4" is maximum). By hand shearing the wool, the lamb may be made to appear more level across the rump. The rump includes the area from the hooks to the dock.

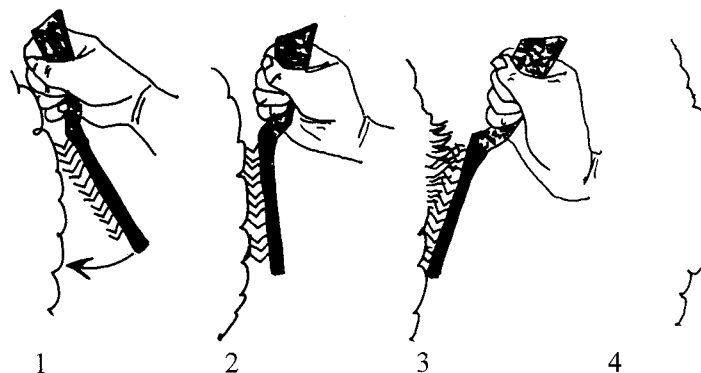

Use the wool card in fitting your lamb: (1) and (2) put card into wool and (3) roll card out of wool. (4) Your carded wool area should look like this. Never try to rake the card through the fleece.

Before hand shearing, dampen the wool with a spray bottle of water. Card the wool with a #2 card. Trim the dock level first and then trim the leg, so the stifle area is the widest part when viewed from the rear. The upper portion of the leg should be trimmed shorter or tighter to bring out the natural bulge of the leg muscles. Always work the hand shears from one point to another, rapidly pulling the top blade back and forth while leaving the bottom blade steady against your thumb.

Diagram 14

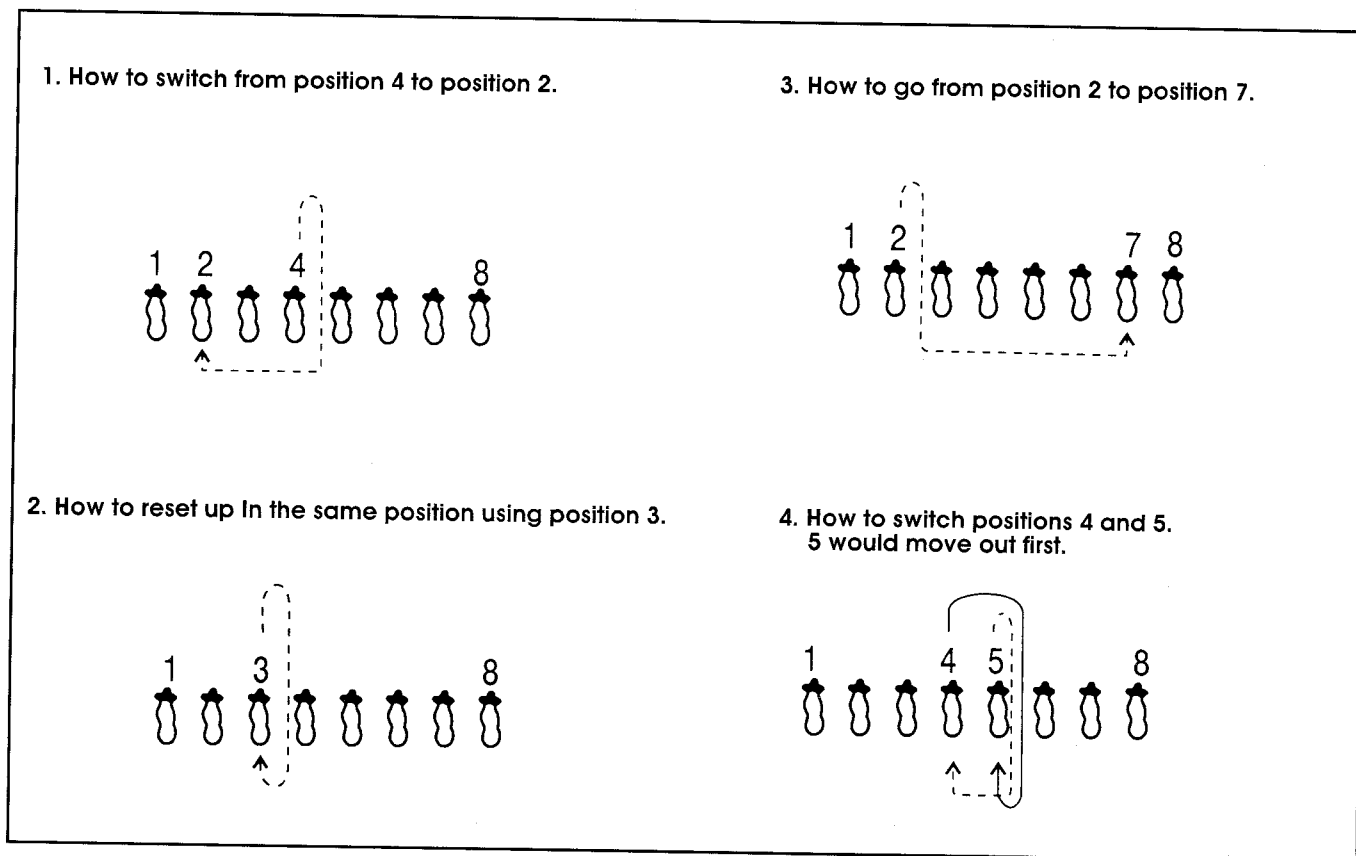

side. If you have to move in the line, Diagram 14 shows what you should do for different situations that may arise. Be sure to line your lamb in a straight line from the first lamb set up as illustrated in Diagram 14.

Once the judge starts giving reasons, the class is over, but exhibitors should continue to work hard and display good sportsmanship. Congratulate the class winners and those who stood ahead of you. Ask if you can handle the lambs that placed above you. This will allow you to learn what to look for in your next lamb project.

Finally, remember this is a learning experience. Leave the ring with your head held high, knowing that you have given this project your best effort. Learn from your mistakes, watch other showpersons, and improve your skills for the next show.

After the Show

Do not neglect your lamb after the show. Before you run off to do something else, care for your lamb first. You must change or remove the show halter and put your lamb in its pen. After the lamb has been penned, let it eat and drink before it settles down to rest. After the lamb is fed and watered, go watch the rest of the show. While watching the show, listen to the judge's comments and analyze the sheep to understand what the judge sees in the lambs. Observe different fitting styles and techniques. These may be helpful in the future. You may see other showmanship styles and methods that may help you control your lamb in the show ring. Observe and try to learn from the show; this is an educational time and one that is fun.

Show Checklist

Livestock

- Rules and regulations of show
- Premium list
- Health papers
- Registration papers
- Rope halters
- Show halters
- Sheep blankets or lamb socks and blanket
- Safety pins
- Farm and pedigree signs

Personal

- Camera and film
- Towels, washcloth, and soap
- Toothbrush and toothpaste
- Lawn chairs
- Washing clothes and rubber boots
- First-aid kit
- Flashlight and batteries
- Safety pin, exhibitor card holder, or clip

Grooming

- Showbox
- Mild soap
- Spray bottle
- Scrub brush
- Currycomb
- #2 wool card
- #1 packing card or rake
- Clippers (flathead and sheepshears), combs,
and cutter blades
- Hand shears
- Extension cords
- 3- or 6-way electrical outlet
- Trimming table or blocking stand
- Lights
- Blower
- Hand sprayers
- Water hose and nozzle
- Towels

Sheep Care

- Feed
- Hay
- Fans and fan stands
- Feed troughs
- Water buckets
- Fly spray
- Bedding
- Hammer and nails
- Wire
- Wrenches, pliers, and screwdriver
- Flavored gelatin or sports drink mix
- Pitchfork, broom, and rake

(A)

TABLE TOP

- 2 EA 1 1/2" x 1 1/2" x 48" ANGLE IRON
- 2 EA 1 1/2" x 1 1/2" x 24" ANGLE IRON
- 3 EA 1 1/2" x 1/8" x 23 3/4" FLAT BAR
- 1 EA 1 1/4" x 1 1/4" x 2 3/4" FLAT BAR
- 1 SH 23 5/8" x 47 5/8" EXPANDED METAL

(B)

NECK BRACE

- 1 EA 1" x 1" x 40 1/4" SQUARE TUBING
- 1 EA 3/16" STEEL PLATE - 2 7/8" x 1 3/4"
- 2 EA 3/8" STEEL ROD - APPROX. 13 1/2" LONG
- 1 EA 1/4" STEEL ROD - 2" LONG
- 1 PC 1/4" PLASTIC CHAIN - APPROX. 15" LONG

(C)

LEG BRACE (2 REQUIRED)

- 4 EA 1" x 1" x 26 1/2" SQUARE TUBING
- 4 EA 1" x 1/8" x 1" FLAT BAR

(D)

LEG ASSEMBLY (2 REQUIRED)

- 4 EA 1" x 1" x 17 7/8" SQUARE TUBING
- 4 EA 1" x 1" x 21 1/2" SQUARE TUBING
- 5 EA 1 1/4" x 1 1/4" x 7" SQUARE TUBING
- 4 EA 1 1/4" x 1/8" x 1 1/4" FLAT BAR
- 2 EA 1 1/2" x 1/8" x 1 1/2" FLAT BAR
- 1 EA 1" x 1" x 7" SQUARE TUBING
- 5 EA 3/8" x 1" HEX HEAD BOLTS
- 5 EA 3/8" HEX HEAD NUTS

MISC. PARTS

- 6 EA 3/8" x 1 3/4" HEX HEAD BOLTS
- 1 EA 3/8" x 2 3/4" HEX HEAD BOLT
- 7 EA 3/8" HEX HEAD NUTS
- 4 EA 1 1/4" x 1/8" x 1 1/4" FLAT BAR

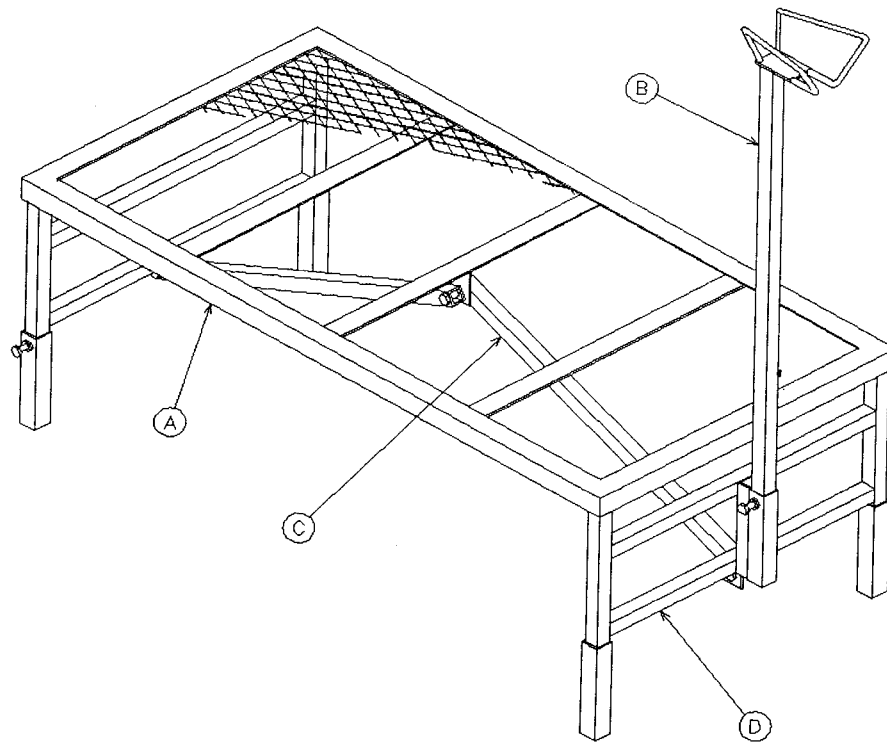

Diagram 15 Plans for Fitting Table.

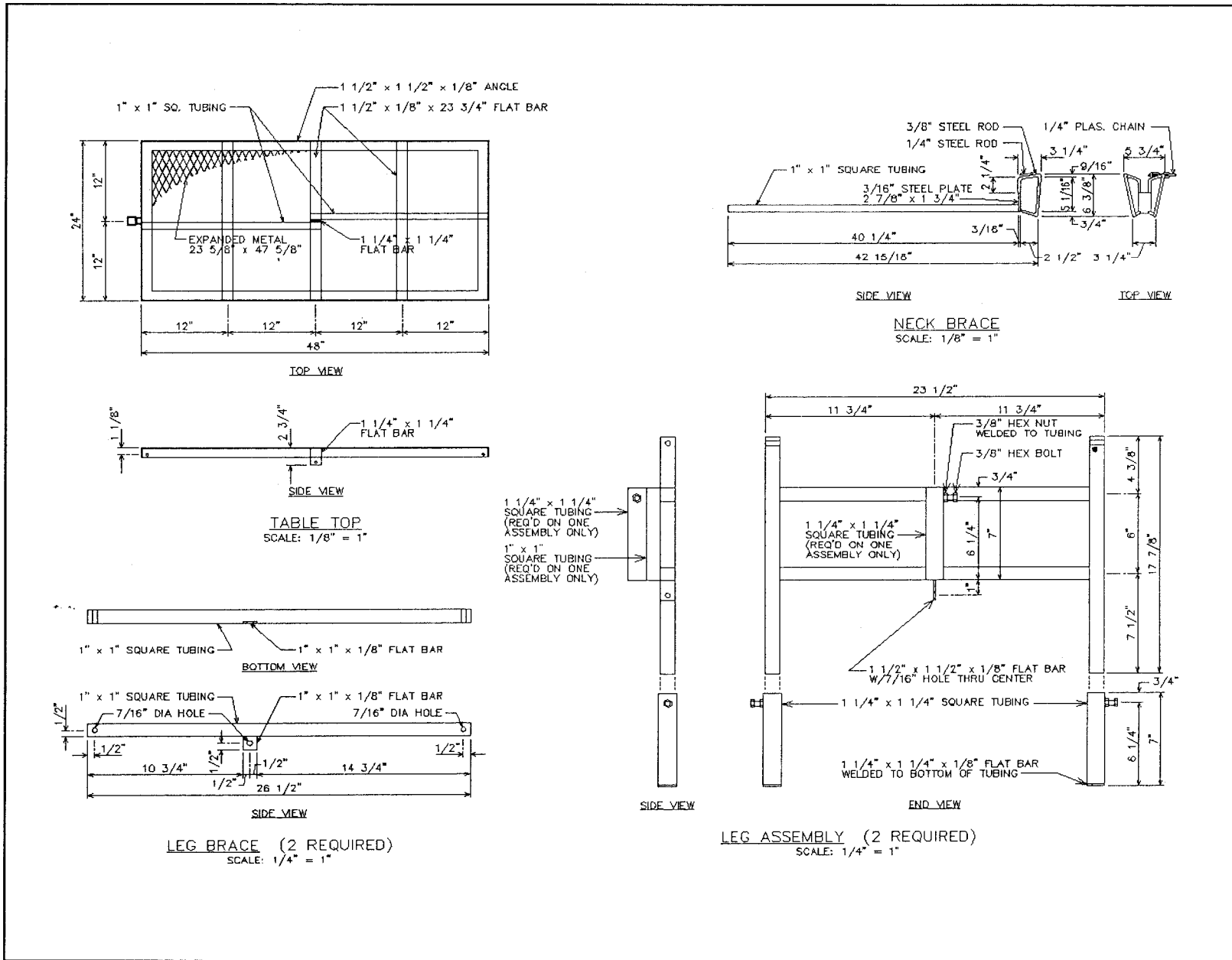

Diagram 16 Plans for Fitting Table.

Glossary

antibiotics—substances produced by fungi, bacteria, and other organisms that are effective in controlling and treating infectious diseases.

bolus—a large pill or large dose of a product.

card—a wire brush-like tool used for fluffing, stretching, or packing wool.

castrated—to make a ram a wether by removal of testes.

Clostridium perfringens—see "enterotoxemia."

Clostridium tetani—see "tetanus."

crude protein—standard unit of measurement used in calculating the amount of protein that an animal should receive in a daily ration.

currycomb—a circular, metal, or hard rubber comb with teeth for cleaning and combing an animal.

deworm—the process of ridding an animal of internal parasites.

dock—the part of the sheep's tail that remains when it is cropped.

drench—a large dose of medicine mixed with liquid and administered in the throat of an animal.

enterotoxemia—overeating disease. Death may result unless an animal is vaccinated for this blood-poisoning disease caused by the toxin *Clostridium perfringens*.

expected daily gain—the amount of weight that an animal is estimated to gain per day when consuming a specific diet.

fine wool—a refined textured wool or fleece.

fleece—the wool coat of a sheep.

genetics—study of heredity and its variations.

injection—a shot. The introduction of a vaccine or other fluid into the body using a needle and syringe.

parasite—an organism living in or on another organism.

paste—a thick liquid substance administered orally.

protein—a nitrogen containing compound that forms an essential nutrient in plants and animals.

rumen—the large first compartment of the stomach of a ruminant animal.

soremouth—a highly contagious viral infection of sheep capable of transmission to man. Virus causes scab formation on the skin usually around the mouth, nostrils, eyes, and other unwooled areas.

TDN (Total Digestible Nutrients)—the standard system for expressing the energy value of a feedstuff.

tetanus (*Clostridium tetani*)—a bacterial disease which results in spasms and stiffness of the muscles.

toxin—a poison produced by an organism in the body.

vaccination—to give a vaccine by injection.

withdrawal time—the amount of time needed for a substance to clear the body to ensure a safe, wholesome meat product.

Retail Cuts of Lamb

Where They Come From and How to Cook Them

<p>SHOULDER</p> <p>① Cubes for Kabobs** — Broil —</p> <p>② Boneless Blade Chops (Saratoga)</p> <p>③ Boneless Shoulder — Roast —</p> <p>④ Cushion Shoulder — Roast —</p> <p>⑤ Square Shoulder — Roast —</p> <p>⑥ Neck Slices — Braise —</p>	<p>RIB</p> <p>① Frenched Rib Chops — Broil, Panbroil, Panfry —</p> <p>② Rib Chops — Broil, Panbroil, Panfry —</p> <p>③ Crown Roast — Roast —</p> <p>④ Rib Roast — Roast —</p>	<p>LOIN</p> <p>① Loin Chops — Broil, Panbroil, Panfry —</p> <p>② Boneless Double Loin Chop — Broil, Panbroil, Panfry —</p> <p>③ Boneless Double Loin Roast — Roast —</p> <p>④ Loin Roast — Roast —</p>	<p>SIRLOIN</p> <p>① Leg Center Slice (Steak) — Broil, Panbroil, Panfry —</p> <p>② Sirloin Chop — Broil, Panbroil, Panfry —</p> <p>③ Boneless Sirloin Roast — Roast —</p> <p>④ Sirloin Roast — Roast —</p>	<p>LEG</p> <p>① Combination Leg — Broil, Panbroil, Panfry —</p> <p>② American-Style Leg — Broil, Panbroil, Panfry —</p> <p>③ Sirloin Half of Leg — Roast —</p> <p>④ Shank Half of Leg — Roast —</p> <p>⑤ French-Style Leg — Roast —</p> <p>⑥ French-Style Leg, Sirloin Off — Roast —</p>
---	--	---	--	---

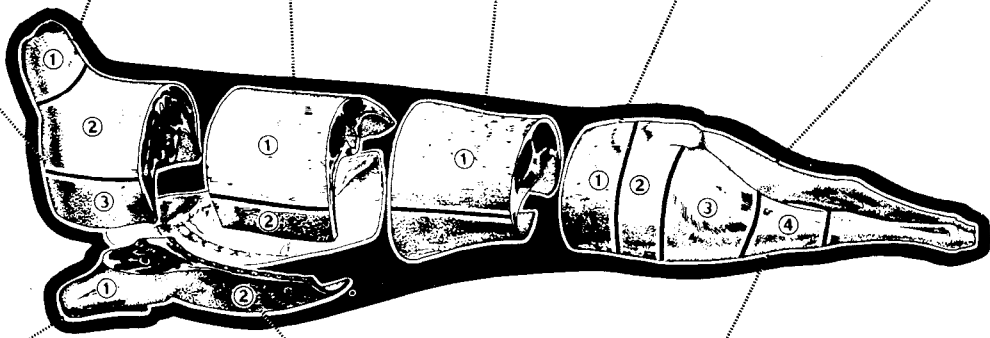

<p>FORE SHANK</p> <p>① Fore Shank — Braise, Cook in Liquid —</p>	<p>BREAST</p> <p>② Breast — Roast, Braise —</p> <p>③ Rolled Breast — Roast —</p> <p>④ Stuffed Breast — Roast —</p>	<p>HIND SHANK</p> <p>④ Hind Shank — Braise, Cook in Liquid —</p>	<p>GROUND OR CUBED LAMB*</p> <p>① (Large Pieces) Lamb for Stew* — Braise, Cook in Liquid —</p> <p>② (Small Pieces)</p>
<p>① Riblets — Braise, Cook in Liquid —</p>	<p>② Boneless Riblets — Braise, Roast (Bake) —</p> <p>③ Spareribs — Braise, Roast (Bake) —</p> <p>④ Stuffed Chops — Broil, Panbroil, Panfry —</p>	<p>① Cubed Steak** — Broil, Panbroil, Panfry —</p> <p>② Lamb Patties* — Broil, Panbroil, Panfry —</p>	<p>③ Ground Lamb* — Roast (Bake) —</p>

* Lamb for stew or grinding may be made from any cut
 ** Kabobs or cubed steaks may be made from any thick solid piece of boneless Lamb.

This chart approved by

National Live Stock and Meat Board

National Live Stock and Meat Board